

DESMI centrifugal pump

NSLH

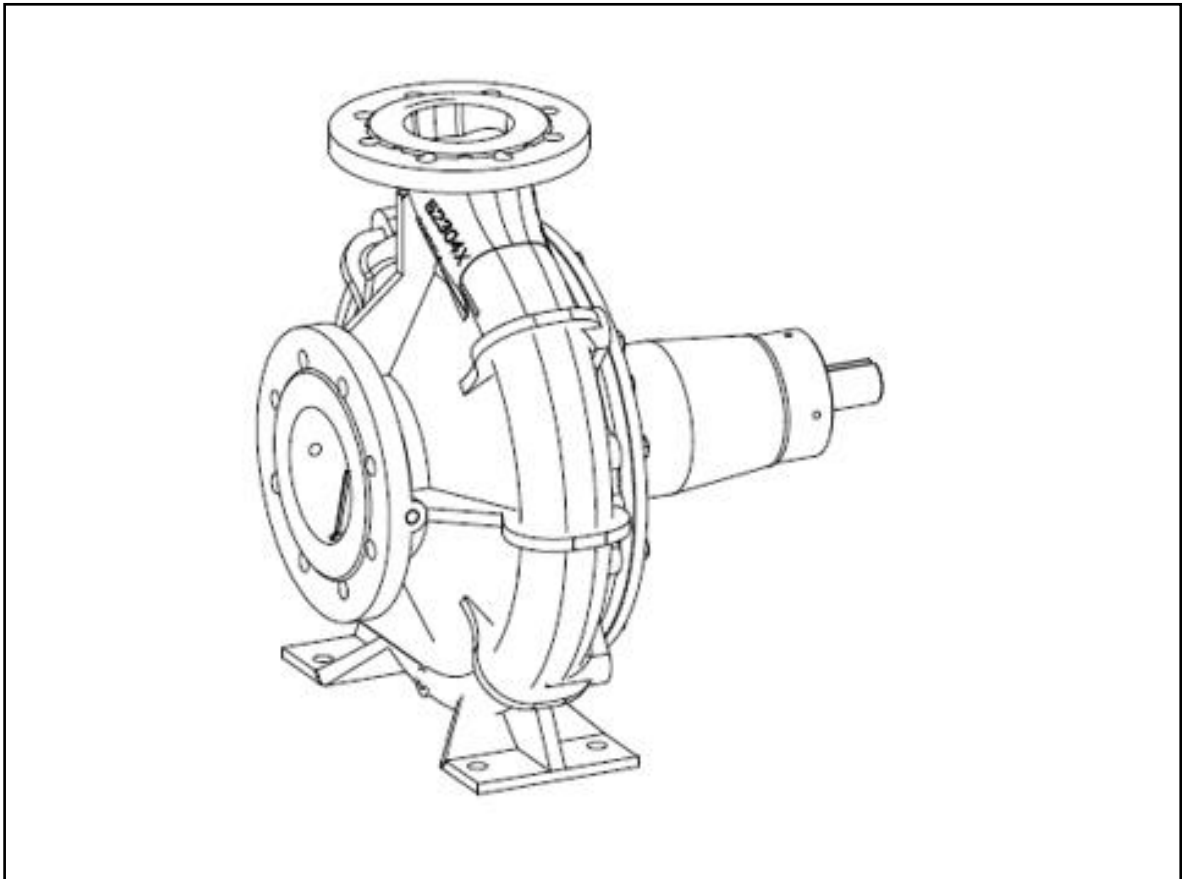

DESMI Pumping Technology A/S
Tagholm 1 – DK-9400 Nørresundby – Denmark

Tel.: +45 96 32 81 11
Fax: +45 98 17 54 99
E-mail: desmi@desmi.com
Internet: www.desmi.com

| | | |
|------------------|----------------------|-----------------------|
| Manual: T1527 | Language: English | Revision: A(08/21) |
|------------------|----------------------|-----------------------|



Special pump No.....

Contents

| | |
|--|-----------|
| 1. PRODUCT DESCRIPTION | 3 |
| 1.1 DELIVERY | 3 |
| 2. TECHNICAL DATA | 3 |
| 2.1 EXPLANATION OF THE TYPE NUMBER | 3 |
| 2.2 TECHNICAL DESCRIPTION | 5 |
| 3. INSTALLATION | 6 |
| 3.1 MOUNTING/FASTENING | 6 |
| 3.2 WIRING | 6 |
| 4. TRANSPORT/STORAGE | 7 |
| 5. DISMANTLING | 8 |
| 5.1 ACCESS TO IMPELLER AND SHAFT SEAL | 8 |
| 5.2 DISMANTLING SHAFT SEAL | 8 |
| 5.3 DISMANTLING SEAT | 8 |
| 5.4 DISMANTLING SHAFT WITH BEARINGS..... | 8 |
| 5.5 INSPECTION | 8 |
| 6. ASSEMBLING | 8 |
| 6.1 FITTING SEALING RING IN PUMP CASING | 8 |
| 6.2 FITTING SHAFT WITH BEARINGS | 8 |
| 6.3 FITTING WATER DEFLECTOR | 9 |
| 6.4 FITTING SHAFT SEAL | 9 |
| 6.5 FITTING IMPELLER | 9 |
| 6.6 FITTING BEARING HOUSING AND SHAFT SEAL COVER | 9 |
| 6.7 SHAFT | 9 |
| 7. FROST PROTECTION | 9 |
| 8. DISMANTLING | 10 |
| 9. START-UP | 10 |
| 9.1 START-UP..... | 10 |
| 10. SYSTEM BALANCING | 11 |
| 11. INSPECTION AND MAINTENANCE | 12 |
| 11.1 DRAINING THE PUMP | 12 |
| 11.2 BEARINGS | 12 |
| 12. REPAIRS | 13 |
| 12.1 ORDERING SPARE PARTS | 13 |
| 13. OPERATING DATA | 14 |
| 14. EU & UK DECLARATION OF CONFORMITY | 15 |
| 15. INFORMATION RELEVANT FOR DISASSEMBLY OR DISPOSAL AT END-OF-LIFE | 16 |
| 16. ASSEMBLY DRAWING FOR PUMPS WITH Ø215 OR Ø265 IMPELLER | 17 |
| 17. SPARE PARTS LIST FOR PUMPS WITH Ø215 OR Ø265 IMPELLER | 17 |
| 18. ASSEMBLY DRAWING FOR Ø330/Ø415/Ø525 /-09 LIGHT BEARING | 18 |
| 19. SPARE PARTS LIST FOR Ø 330/Ø415/Ø525 /-09 LIGHT BEARING | 18 |
| 20. ASSEMBLY DRAWING FOR Ø 330/Ø415/Ø525 /-09 HEAVY BEARING | 19 |
| 22. DIMENSIONAL SKETCH, NSLH100-330 | 20 |
| 23. SUBSIDIARY AND SERVICE IN DENMARK | 21 |

1. PRODUCT DESCRIPTION

These operation and maintenance instructions apply to the DESMI NSLH pump series. The pumps are available in sizes ranging from 65 to 300 mm on the discharge flange. The suction flange is bigger than the discharge flange.

The DESMI NSLH is a single-stage centrifugal pump with stainless steel shaft, mechanical shaft seal, and closed impeller.

The pump is suitable for the pumping of clean and polluted liquids with temperatures between 0 and 80°C. With special shaft seal up to 140°C. Max. number of revolutions: 3600 RPM.

For pumping liquids with temperatures above 100°C DESMI recommends using nothing but ductile iron (for instance GGG40) for pump casing and rear cover. Max. working pressure and number of revolutions are listed in section 13. OPERATING DATA.

The back and the front of the impeller are equipped with sealing rings and relief holes to reduce the load on the bearings. The pump inlet and outlet are tangential i.e. the line through inlet and outlet is offset in relation to the centre line of the shaft.

The pump has horizontal inlet on the centre line and vertical outlet at the top.

1.1 DELIVERY

- Check on delivery that the shipment is complete and undamaged.
- Defects and damages, if any, to be reported to the carrier and the supplier immediately in order that a claim can be advanced.

2. TECHNICAL DATA

The pumps are manufactured in various material combinations which are specified in the type number on the name plate. See below.

2.1 EXPLANATION OF THE TYPE NUMBER

All the NSLH pumps are provided with a name plate. The type number indicated on the name plate is structured as follows:

NSLHXXX-YYY/MR-Z

XXX: Pressure branch diameter.

YYY: Standard impeller diameter.

M: The material combination of the pump.

R: The assembly combination of the pump.

Z: Other variants

M options:

- A: Casing and shaft seal cover : Cast iron + cast iron alloy. Impeller and sealing rings: NiAlBz
- B: Casing and shaft seal cover: Cast iron + cast iron alloys. Impeller and sealing rings: Stainless.
- C: All cast iron
- D: Casing and shaft seal cover: Bronze or NiAlBz. Impeller and sealing rings: NiAlBz or stainless steel
- E: Casing and shaft seal cover: NiAlBz and bronze alloy. Impeller and sealing rings: NiAlBz

The pumps can be delivered in other material combinations according to agreement with the supplier.

R options:

- 02: Monobloc, with bearing in the pump
- 03: Mounted with hydraulic motor
- 07: Mounted on base plate with electric motor
- 09: Pump with bare shaft end
- 12: Monobloc, without bearing in the pump
- 13: Spacer, light bearing housing
- 14: Spacer, heavy bearing housing
- 15: Spacer, heavy bearing housing and heavy motor bracket (special motor bracket)

Z options:

- i: PN16 flanges
- j: PN25 flanges
- k: Special flange
- l: Other shaft seal
- m: BS flanges
- n: ANSI flanges
- o: Shockproof design
- p: Other design
- q: JIS flanges
- r: With inducer

Any use of the pump is to be evaluated on the basis of the materials used in the pump. In case of doubt, please contact DESMI.

Pumps in material combinations A and C are primarily used for fresh water.
Pumps in material combination D and E are primarily used for seawater.

If the pumps are designed for special purposes the following is to be indicated:

Pump No. :
Pump type :
Application :
Comment :

2.2 TECHNICAL DESCRIPTION

The noise level indicated is the airborne noise including the motor. The noise depends on the motor type supplied, as the noise from the pump can be calculated as the noise level of the motor + 2dB(A). The noise level is for pumps with electric motors.

The capacity of the pump appears from the name plate on the pump. If the pump has been delivered without motor, the pump capacity is to be indicated on the plate when mounting the motor.

The permissible loads on the flanges appear from the following table. The values apply to standard pumps in bronze (Rg5) and cast iron (GG20). As to pumps in SG iron (GGG40) or NiAlBz the values are to be increased by a factor 1.5.

| Pump size | Fy N | Fz N | Fx N | ∑F | My Nm | Mz Nm | Mx Nm | ∑Mt |
|--|---------|---------|---------|------|----------|----------|----------|------|
| 65-215 65-265 | 650 | 840 | 750 | 1340 | 510 | 310 | 380 | 700 |
| 80-215 80-265 80-330 | 800 | 950 | 850 | 1500 | 550 | 350 | 400 | 750 |
| 100-215 100-265 100-330 100-415 | 1000 | 1250 | 1150 | 2000 | 650 | 400 | 500 | 900 |
| 125-215 125-265 125-330 125-415 | 1250 | 1600 | 1430 | 2500 | 830 | 520 | 650 | 1160 |
| 150-265 150-330 150-415 | 1500 | 1900 | 1700 | 2950 | 1000 | 650 | 800 | 1400 |
| 200-265 200-330 200-415 200-525 | 2000 | 2520 | 2260 | 3920 | 1330 | 860 | 1060 | 1860 |
| 250-330 250-415 250-525 | 2500 | 3150 | 2820 | 4900 | 1770 | 1140 | 1400 | 2470 |
| 300-415 300-525 | 3000 | 3750 | 3350 | 5860 | 2750 | 1900 | 2200 | 4000 |

Table 1 Permissible loads

In connection with the permissible loads on the flanges the following is to be observed:

$$\left(\frac{\sum F_{calc}}{\sum F} \right)^2 + \left(\frac{\sum M_{calc}}{\sum M_t} \right)^2 < 2$$

where index "calc" is the values calculated by the user.

At the same time none of the forces or moments may exceed the indicated figure multiplied by 1.4.

3. INSTALLATION

3.1 MOUNTING/FASTENING

The pump should be mounted and fastened on a solid base plate with a flat and horizontal surface to avoid distortion.

The max. permissible loads on the flanges stated in Table 1 on page 5 must be observed.

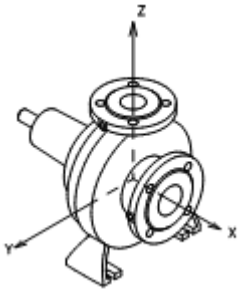

Figure 1 Load on flanges

The following should be observed:

- Avoid distortion of the base plate.
- Avoid distortion in the piping system.
- Check that pump and motor are aligned correctly.



When connecting the pump and a prime mover the power transmission is to be equipped with a guard in accordance with the EC safety requirements (see section 14. EU & UK DECLARATION OF CONFORMITY).

At installations pumping hot or very cold liquids, the operator must be aware that it is dangerous to touch the pump surface, and, consequently, he must take the necessary safety measures.

3.2 WIRING



Wiring to be carried out by authorized skilled workmen according to the rules and regulations in force.

4. TRANSPORT/STORAGE

| Pump size | Material code A / code D | Pump size | Material code A / code D |
|-----------------|--------------------------|-----------------|--------------------------|
| NSLH65-215/-09 | 60 / 71.5 kg | NSLH150-330/-09 | 200 / 208 kg |
| NSLH65-265/-09 | 67 / 78 kg | NSLH150-415/-09 | 235 / 263 kg |
| NSLH80-330/-09 | 117 / 126 kg | NSLH150-265/-09 | 131 / 150 kg |
| NSLH80-215/-09 | 70 / 76 kg | NSLH200-330/-09 | 236 / 250 kg |
| NSLH80-265/-09 | 78 / 90 kg | NSLH200-415/-09 | 260 / 303 kg |
| NSLH100-330/-09 | 125 / 131 kg | NSLH200-525/-09 | 433 / 470 kg |
| NSLH100-415/-09 | 223 / 237 kg | NSLH200-265/-09 | 167 / 181 kg |
| NSLH100-215/-09 | 89 / 100 kg | NSLH250-330/-09 | 283 / 330 kg |
| NSLH100-265/-09 | 106 / 114 kg | NSLH250-415/-09 | 326 / 372 kg |
| NSLH125-330/-09 | 136 / 154 kg | NSLH250-525/-09 | 477 / 540 kg |
| NSLH125-415/-09 | 228 / 243 kg | NSLH300-415/-09 | 394 / 455 kg |
| NSLH125-215/-09 | 118 / 130 kg | NSLH300-525/-09 | 605 / 683 kg |
| NSLH125-265/-09 | 126 / 142 kg | | |

Table 2 pump weight

The weights of the pumps in code E are decreased by factor 0.9 compared to pumps in D code.

The pump must be stored in a dry area.

Before shipment the pump is to be fastened securely on pallets or the like.
The pump must be lifted as shown below:

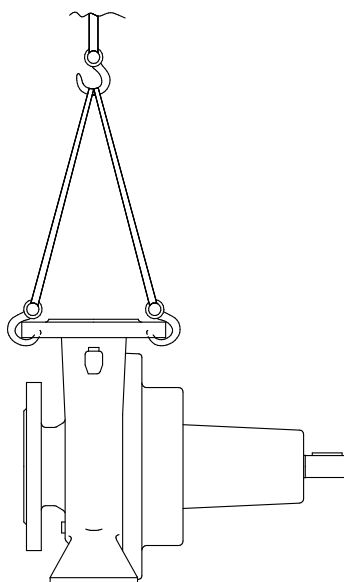

Figure 2 Lifting the pump



The lifting straps must not bear against sharp edges and corners

5. DISMANTLING

5.1 ACCESS TO IMPELLER AND SHAFT SEAL

Remove Hex screws (22), which hold the shaft seal cover to the pump casing, and pull the bearing housing to remove the complete bearing housing with impeller, bearings, and shaft.

5.2 DISMANTLING SHAFT SEAL

Remove the Set screw (6) (Nut in $\varnothing 215$ or $\varnothing 265$). Pull off the impeller. Remove the Hex screws (19), which hold the bearing housing to the shaft seal cover, pull shaft seal cover and bearing housing apart, by which shaft seal and water deflector are pulled off the shaft.

5.3 DISMANTLING SEAT

Press out the seat from behind the shaft seal cover.

5.4 DISMANTLING SHAFT WITH BEARINGS

Before dismantling the shaft with bearings, remove the sunk key (16). The shaft can now be pulled out of the bearing housing allowing inspection of the bearings.

5.5 INSPECTION

When the pump has been dismantled, check the following parts for wear and damage:

- Sealing ring/impeller: Max. clearance 0.4-0.5 mm measured in radius.
- Shaft seal/shaft seal cover: Check the seat for flatness and cracks.
Check the rubber parts for elasticity.
- Bearings: Replace in case of wear and noise.

6. ASSEMBLING

6.1 FITTING SEALING RING IN PUMP CASING

When fitted, the sealing ring is to bear against the shoulder of the pump casing.

6.2 FITTING SHAFT WITH BEARINGS

Lead shaft with bearings into the bearing housing. Fit sunk key (16).

6.3 FITTING WATER DEFLECTOR

Assemble the bearing housing and the shaft seal cover. Lead the water deflector over the shaft until it touches the shaft seal cover and then further 1-1.5 mm into the shaft seal cover.

6.4 FITTING SHAFT SEAL

Before fitting the seat, clean the recess in the shaft seal cover. When fitting the seat, remove the protective coating without scratching the lapped surface. Dip the outer rubber ring of the seat into olive oil (or another neutral oil) or soapy water. Now press the seat into place with the fingers and check that all parts are correctly imbedded.

If it is necessary to use tools for assembling, then protect the sliding surface of the seat to prevent it from being scratched or cut.

Lubricate the inner diameter of the slide ring rubber bellows with olive oil or soapy water and push it over the shaft. The use of a fitting bush as shown on the assembly drawing is recommended to avoid that the rubber bellows is cut. Push the slide ring over the shaft with the hand. If the rubber bellows is tight, use a fitting tool and take care that the slide ring is not damaged.

If the carbon ring is not fixed, it is important to check that it is fitted correctly, i.e. the chamfered/lapped side is to face the seat. The carbon ring can be held by a little grease.

When using oil on the shaft, the bellows will settle and seat in about 15 minutes, and until then tightness should not be expected. After start, check by viewing the leak hole that there are no leaks.

6.5 FITTING IMPELLER

Fit the sunk key in the shaft and lead the impeller towards the shoulder of the shaft. Take care that the ring at the end of the shaft seal spring locates in the recess of the impeller. Secure the impeller with a washer and a set screw.

6.6 FITTING BEARING HOUSING AND SHAFT SEAL COVER

Place the gasket between pump casing and shaft seal cover on the shaft seal cover where it can be held with a little grease. Fit and fasten bearing housing with shaft seal cover. Check that the drain passage for the shaft seal faces downwards.

6.7 SHAFT

When the pump has been assembled, check that the shaft rotates freely.

7. FROST PROTECTION

Pumps which are not in operation during frost periods are to be drained to avoid frost damage. Remove the plug at the bottom to empty the pump. Alternatively, it is possible to use anti-freeze liquids in normal constructions.

8. DISMANTLING



Before dismantling the pump make sure that it has stopped. Empty the pump of liquid before it is dismantled from the piping system. If the pump has been pumping dangerous liquids be sure that you take the appropriate safety precautions before dismantling it.

If the pump has been pumping hot liquids, take great care that it is drained before it is removed from the piping system.

9. START-UP



A centrifugal pump will not function until it has been filled with liquid between the foot valve and somewhat above the impeller of the pump.

The liquid also serves as coolant for the shaft seal. In order to protect the shaft seal the pump must not run dry.

ATTENTION!

For safety reasons the pump is only allowed to operate against closed discharge valve for a short time (max. 5 minutes and at a max. temperature of 80°C for standard pumps). Otherwise there is a risk of damage to the pump and, at worst, of a steam explosion. If the pump is not monitored, the installation of a safety device is recommended.

Check in the electric motor manual if the bearings in the actual motor shall be lubricated with grease before first start-up.

On pumps not running the shaft shall be rotated at least 2-3 times monthly to avoid standstill damage to shaft seal and bearings. If the pump is filled with liquid it can alternatively be started up shortly.

In special applications, it may require more frequent shaft rotation or start-up in order to avoid seizing of the impeller and/or the shaft seal.

In pressurized systems the shaft seal often leaks a bit during standstill – in most cases the leakage stops shortly after the pump is started up.

It is not recommended to lead liquid (either one way or the other) through a passively rotating pump, as this may damage the shaft seal.

For the sake of the shaft seal lifetime, it is recommended to run at least 300 rpm and use max. 1 minute on acceleration from 0 to 300 rpm and max. 1 minute on deceleration from 300 to 0 rpm.

9.1 START-UP

Before starting the pump check that:

- the shaft rotates freely without jarring sounds.
- the pump casing and the suction line are filled with liquid.

Start the pump for a moment to check the direction of rotation. If the direction is correct (i.e. in the direction of the arrow) the pump may be started.

10. SYSTEM BALANCING

It is often difficult to calculate a manometric delivery head in advance. It is, however, decisively important to the quantity of liquid delivered.

A considerably smaller delivery head than expected will increase the quantity of liquid delivered, causing increased power consumption and perhaps cavitation in pump and piping. In the pump the impeller may show signs of heavy erosion caused by cavitation (corrosion) which may at times render an impeller unfit for use in a very short time. Not unusually do similar erosions occur in pipe bends and valves elsewhere in the piping system.

Therefore, after start-up, it is necessary to check either the quantity of liquid delivered or the power consumption of the pump e.g. by measuring the current intensity of the connected motor. Together with a reading of the differential pressure the quantity of water delivered can be determined against the characteristics of the pump.

Should the pump not function as intended, please proceed according to the fault-finding list below. Bear in mind, though, that the pump was carefully checked and tested at the factory and that the majority of faults stem from the piping system.

| Fault | Cause | Remedy |
|--|--|---|
| The pump has no or too low capacity | Wrong direction of rotation | Change direction of rotation to clockwise when viewed from shaft end (the direction of the arrow) |
| | Piping system choked | Clean or replace |
| | The pump is choked | Clean the pump |
| | Suction line leaks | Find the leakage and repair the fault. The non-return valve is not submerged |
| | The pump takes in air | |
| | Suction lift too high | Check data sheet Q/H curve and NPSH or contact DESMI |
| Pump and piping system wrongly dimensioned | Check data sheet Q/H curve and NPSH or contact DESMI | |
| The pump uses too much power | Counter-pressure too low | Insert orifice plate or check valve/contact DESMI |
| | The liquid is heavier than water | Contact DESMI |
| | Foreign body in pump | Dismantle the pump, remove the cause |
| | Electric motor is running on 2 phases | Check fuses, cable connection, and the cable |
| The pump makes noise | Cavitation in pump | Suction lift too high/ Suction line wrongly dimensioned/ Liquid temperature too high |

Table 3 Fault-finding list

11. INSPECTION AND MAINTENANCE

Inspect the shaft seal for leaks at regular intervals.

Before inspection of a pump without guard check that the pump cannot be started unintentionally. The system must be without pressure.

The repairman must be familiar with the type of liquid which has been pumped as well as the safety measures he must take when handling the liquid.

On Monobloc pumps with bearing (/ -02 design), the drain hole at the mechanical shaft seal must be inspected regularly (see drawing example below). Clean the drain hole as needed. If the drain hole clogs up, leaking liquid and/or vapors from the shaft seal can be forced up into the bearing unit, which can result in a much shorter bearing life than normal.

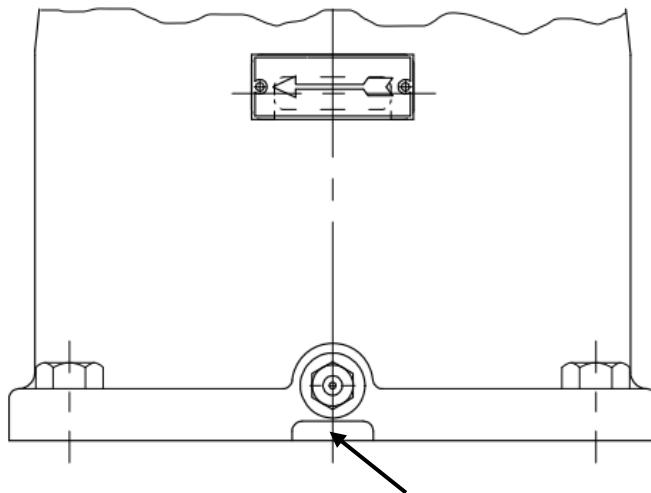

DRAIN HOLE FOR SHAFT SEAL

11.1 DRAINING THE PUMP

When the piping system has been drained, note that there is still liquid in the pump. Remove the liquid by dismantling the pipe plug (3) at the bottom of the pump.

11.2 BEARINGS

The bearings are lubricated for life and require no attention but are to be replaced in case of noise or bearing wear.

DESMI use SKF LGHP2 as standard.

Note that relubrication can cause a (usually temporary) bearing temperature rise of up to approx. 20 ° C - especially by mixing different types of grease and / or by overlubricating the bearing.

Grease used for relubrication must be compatible with the grease in the bearing unit.

12. REPAIRS

12.1 ORDERING SPARE PARTS

When ordering spare parts please always state pump type, serial No. (appears on the name plate of the pump), position No. on the assembly drawing and designation on the spare parts list.

13. OPERATING DATA

The following working pressures (pressure in piping incl. the pressure increase caused by the pump) and number of revolutions are allowed in standard pumps:

| Pump size | Max. working pressure [bar] Bronze/ Cast iron | Max. working pressure [bar] SG-iron | Max. RPM Light/heavy bearing housing | Pump size | Max. working pressure [bar] Bronze/ Cast iron | Max. working pressure [bar] SG-iron | Max. RPM Light/heavy bearing housing |
|----------------|---|--|---|----------------|---|--|---|
| 65-215 | 16 | 25 | 1800 / 3600 | 150-330 | 7 / 13 | 25 | 1800 / 1800 |
| 65-265 | 14.5 | 25 | 1800 / 3600 | 150-415 | 9/13 | 25 | 1800 / 1800 |
| 80-330 | 15/15 | 25 | 3600 / 3600 | 150-265 | 10 | 25 | 1800 / 1800 |
| 80-215 | 13 | 25 | 1800 / 3600 | 200-330 | 7 / 13 | 25 | 1800 / 1800 |
| 80-265 | 14.5 | 25 | 1800 / 3600 | 200-415 | 9/13 | 25 | 1800 / 1800 |
| 100-330 | 8 / 14 | 25 | 3000 / 3000 | 200-265 | 10/12.5 | 25 | 1800 / 1800 |
| 100-415 | 10/12.5 | 25 | 1800 / 1800 | 200-525 | 14 | 25 | 1800 / 1800 |
| 100-215 | 12.5 | 25 | 1800 / 3600 | 250-330 | 7 / 12 | 25 | 1800 / 1800 |
| 100-265 | 14.5 | 25 | 1800 / 3600 | 250-415 | 9 / 12 | 25 | 1800 / 1800 |
| 125-330 | 7 / 12 | 25 | 1800 | 250-525 | 14 | 25 | 1800 / 1800 |
| 125-415 | 9/13 | 25 | 1800 / 1800 | 300-415 | 9 / 12 | 25 | 1800 / 1800 |
| 125-215 | 8 | 25 | 1800 / 1800 | 300-525 | 14 | 25 | 1800 / 1800 |
| 125-265 | 7 | 25 | 1800 / 1800 | | | | |

Table 4 Operating data

Notice: Some pump combinations allow higher speeds than stated in the table – see actual pump name plate.

The max. working pressure for NiAlBz and stainless steel pumps is 1.5 times max. working pressure for bronze (RG5).

The above-mentioned max. working pressure is a design value – delivered pumps are pressure tested according to actual application requirements and actual flange standards.

The above-mentioned max. working pressure is **NOT** valid for pumps approved by a classification society. Pumps approved by classification societies have been pressure tested according to the requirements of these societies, i.e. a test pressure of 1.5 x the permissible working pressure. The test pressure is stated in the test certificate and stamped into the discharge flange of the pump.

14. EU & UK DECLARATION OF CONFORMITY

DESMI Pumping Technology A/S, hereby declare that our pumps of the NSLH type are manufactured in conformity with the following essential safety and health requirements in the COUNCIL DIRECTIVE 2006/42/EC on machines, Annex 1.

The following harmonized standards have been used:

| | |
|------------------------------------|---|
| EN/ISO 13857:2008 | Safety of machinery. Safety distances to prevent danger zones being reached by the upper limbs |
| EN 809:1998 + A1:2009 | Pumps and pump units for liquids – Common safety requirements |
| EN12162:2001+A1:2009 | Liquid pumps – Safety requirements – Procedure for hydrostatic testing |
| EN 60204-1:2006/A1:2009 | Safety of machinery – Electrical equipment of machines (item 4, General requirements) |
| Ecodesign Directive (2009/125/EC). | Water pumps: Commission Regulation No 547/2012. Applies only to water pumps marked with the minimum efficiency index MEI. See pump nameplate. |

Pumps delivered by us connected with prime movers are CE-marked and comply with the above requirements.

Pumps delivered by us without prime movers (as partly completed machinery) must only be used when the prime mover and the connection between prime mover and pump comply with the above requirements.

Nørresundby, August 12 2021



Henrik Mørkholt Sørensen
Managing Director

DESMI Pumping Technology A/S
Tagholm 1
9400 Nørresundby

15. INFORMATION RELEVANT FOR DISASSEMBLY OR DISPOSAL AT END-OF-LIFE

No damage materials are used in DESMI pumps – please refer to DESMI Green Passport (can be sent on request – contact a DESMI sales office) – i.e. common recycling companies can handle the disposal at end-of-life. Alternatively the pump and motor can be returned to DESMI at end-of-life for safe recycling.

16. ASSEMBLY DRAWING for pumps with $\varnothing 215$ or $\varnothing 265$ impeller

Regarding pumps with $\varnothing 330/\varnothing 415/\varnothing 525$ impeller - see next pages.

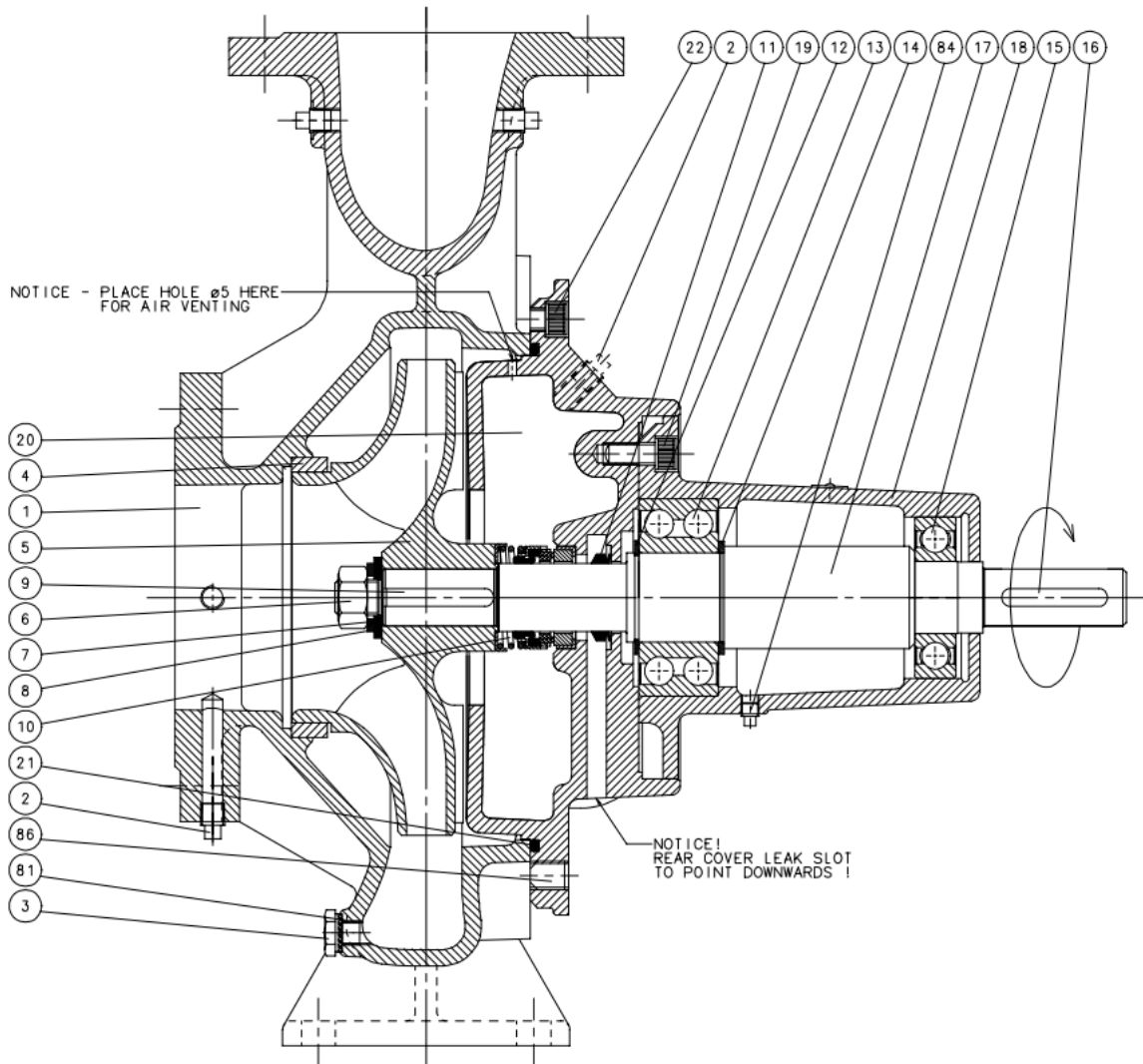

17. SPARE PARTS LIST for pumps with $\varnothing 215$ or $\varnothing 265$ impeller

| Pos. | Part | Pos. | Part |
|------|-----------------------|------|---------------------------------|
| 1 | Pump casing | 14 | Support disc |
| 2 | Pipe plug | 15 | Ball bearing |
| 3 | Pipe plug | 16 | Sunk key |
| 4 | Sealing ring | 17 | Shaft |
| 5 | Impeller | 18 | Bearing housing |
| 6 | Nut | 19 | Allen screw |
| 7 | Spring collar | 20 | Shaft seal cover |
| 8 | Washer | 21 | O-ring |
| 9 | Sunk key | 22 | H Allen screw |
| 10 | Mechanical shaft seal | 81 | Sealing washer |
| 11 | Water deflector | 84 | Grease nipple/Lubricator nipple |
| 12 | Ring lock | 86 | Point screw |
| 13 | Ball bearing | | |

Table 5 Spare parts list for pump with $\varnothing 215$ or $\varnothing 265$ impeller

18. ASSEMBLY DRAWING for Ø330/Ø415/Ø525 /-09 light bearing

See heavy bearing on the next page.

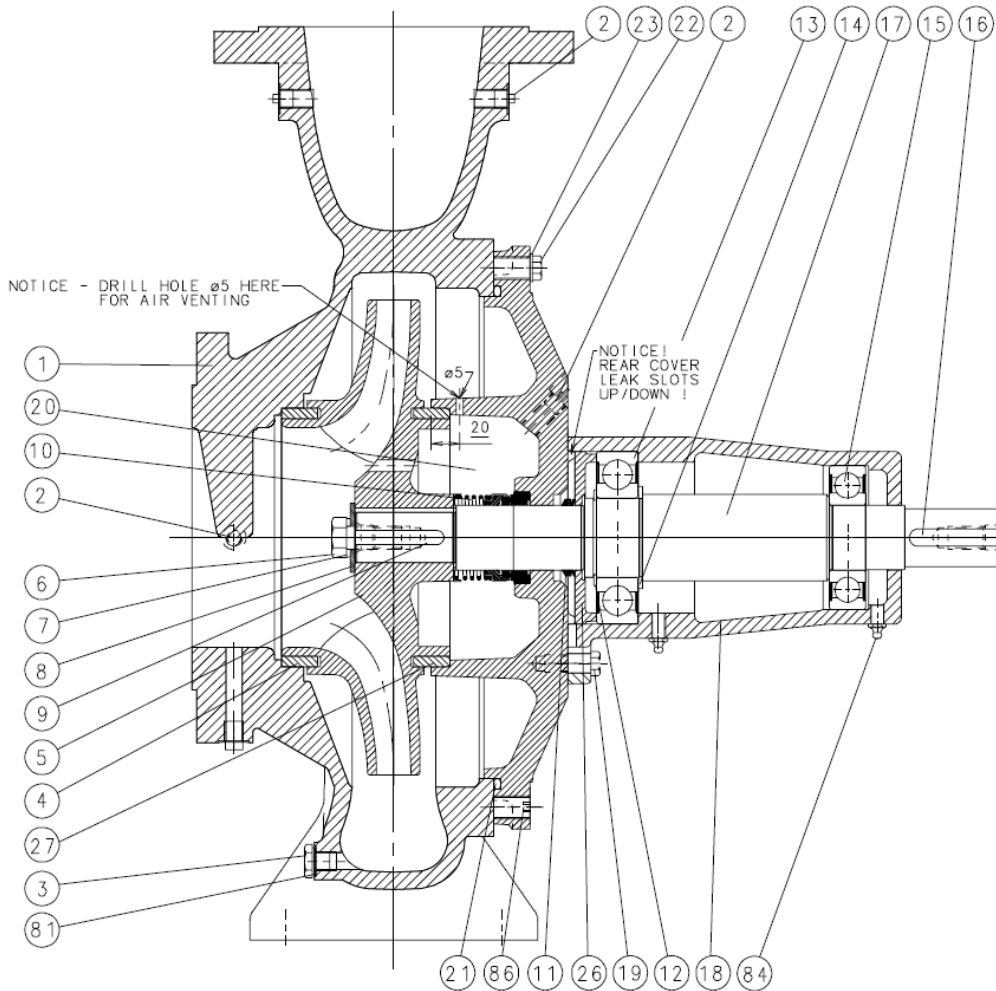

19. SPARE PARTS LIST for ø 330/Ø415/Ø525 /-09 light bearing

| Pos. | Part | Pos. | Part |
|------|-----------------------|------|---------------------------------|
| 1 | Pump casing | 16 | Sunk key |
| 2 | Pipe plug | 17 | Shaft |
| 3 | Pipe plug | 18 | Bearing housing |
| 4 | Sealing ring | 19 | Hex screw |
| 5 | Impeller | 20 | Shaft seal cover |
| 6 | Set screw | 21 | O-ring |
| 7 | Spring collar | 22 | Hex screw |
| 8 | Washer | 23 | Washer |
| 9 | Sunk key | 26 | Cover u. bearing |
| 10 | Mechanical shaft seal | 27 | Pipe plug |
| 11 | Water deflector | 80 | Sealing washer |
| 12 | Ring lock | 81 | Sealing washer |
| 13 | Ball bearing | 82 | Sealing washer |
| 14 | Support disc | 84 | Grease nipple/Lubricator nipple |
| 15 | Ball bearing | 86 | Point screw |

Table 6 Spare parts list for ø330/Ø415/Ø525 /-09 light bearing

20. ASSEMBLY DRAWING for Ø 330/ø415/ø525 /-09 heavy bearing

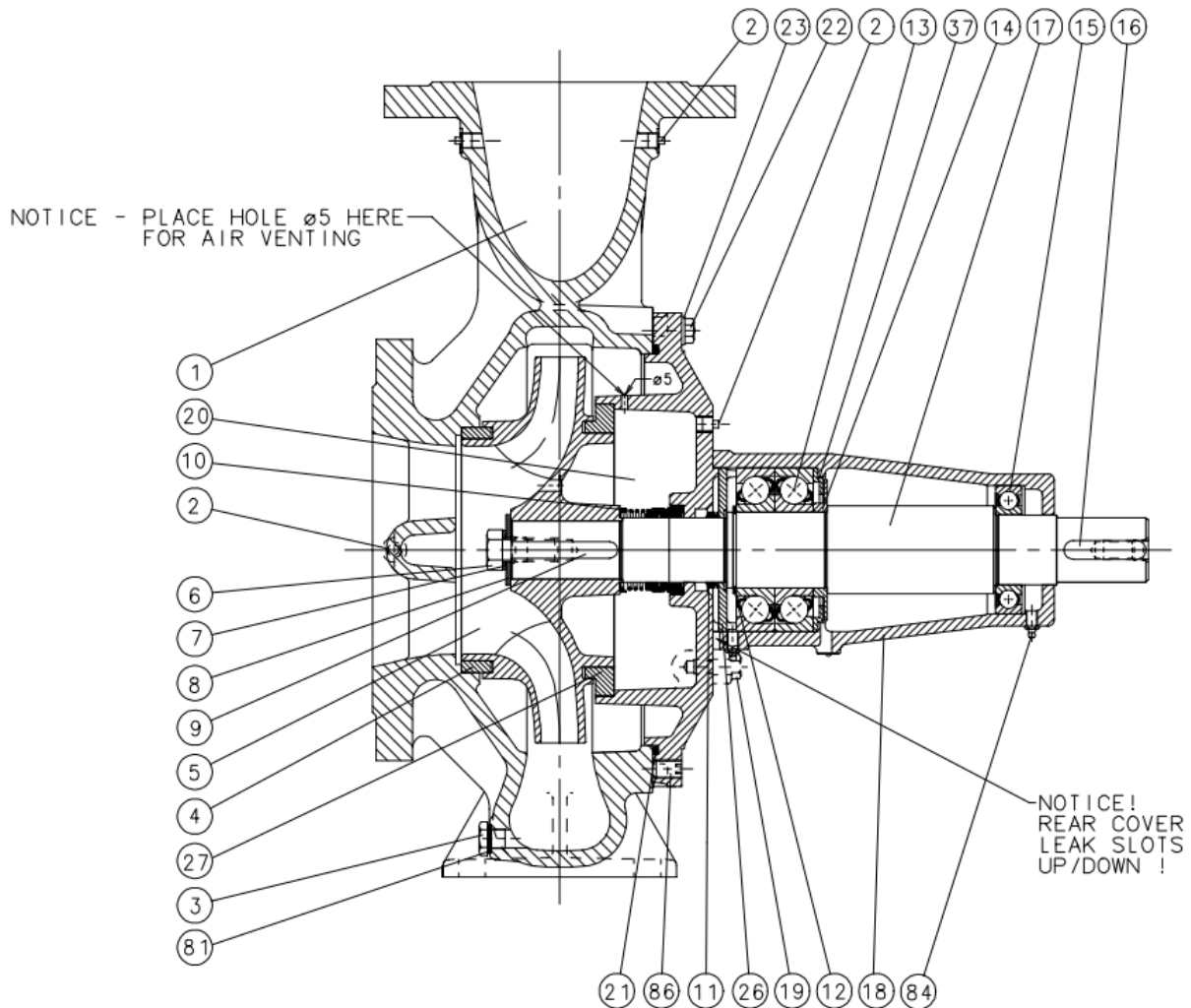

21. SPARE PARTS LIST for ø330/ø415/ø525 /-09 heavy bearing

| Pos. | Part | Pos. | Part |
|------|-----------------------|------|---------------------------------|
| 1 | Pump casing | 16 | Sunk key |
| 2 | Pipe plug | 17 | Shaft |
| 3 | Pipe plug | 18 | Bearing housing |
| 4 | Sealing ring | 19 | Hex screw |
| 5 | Impeller | 20 | Shaft seal cover |
| 6 | Set screw | 21 | O-ring |
| 7 | Spring collar | 22 | Hex screw |
| 8 | Washer | 23 | Washer |
| 9 | Sunk key | 26 | Cover u. bearing |
| 10 | Mechanical shaft seal | 27 | Sealing ring |
| 11 | Water deflector | 37 | Grease regulator |
| 12 | Ring lock | 81 | Sealing washer |
| 13 | Ball bearing | 84 | Grease nipple/Lubricator nipple |
| 14 | Support disc | 86 | Point screw |
| 15 | Ball bearing | | |

Table 7 Spare parts list for ø330/ø415/ø525 /-09 heavy bearing

22. DIMENSIONAL SKETCH, NSLH100-330

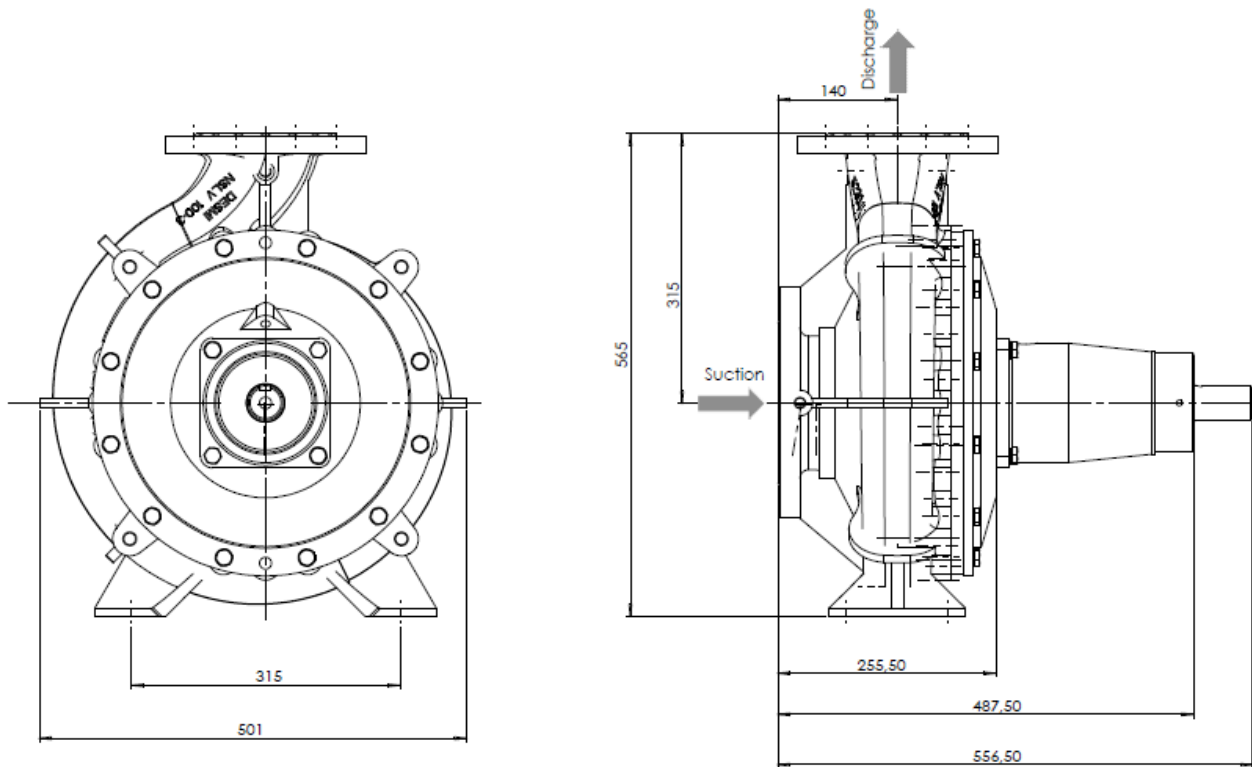

Flanges dimensions:

Suction flange DN125 - PN16

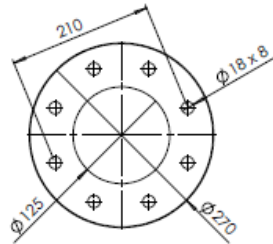

Discharge flange DN100 - PN16

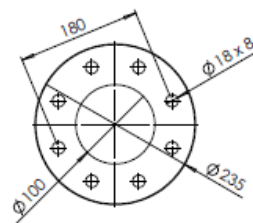

Figure 3 Dimensional sketch NSLH100-330

Please contact DESMI regarding dimensions for other pump sizes.

23. SUBSIDIARY AND SERVICE IN DENMARK

| Subsidiary companies – DESMI Pumping Technology A/S | | | | |
|--|--|----------------|-------------------------------------|---------------------|
| Company Name | Address | Country | Telephone | Fax |
| DESMI Pumping Technology (Suzhou) Co.,Ltd. | No. 740 Fengting Avenue Weiting Sub District 215122 SIP Suzhou, P. R. China | China | +86 512 6274 0400 | +86 512 6274 0418 |
| DESMI Danmark A/S DESMI Contracting A/S DESMI Ocean Guard A/S | Tagholm 1 9400 Nørresundby | Denmark | +45 9632 8111 | +45 9817 5499 |
| DESMI GmbH | An der Reitbahn 15 D-21218 Seevetal | Germany | +49 407 519847 | +49 407 522040 |
| DESMI B.V | Texasdreef 7 3565 CL Utrecht | Netherlands | +31 302610024 | +31 302623314 |
| DESMI Norge AS | Skibåsen 33 h 4636 Kristiansand | Norway | +47 3812 2180 | +47 3804 5938 |
| DESMI Ltd. | "Norman House", Rosevale Business Park Parkhouse Industrial Estate (West) Newcastle Staffordshire ST5 7UB | United Kingdom | +44 1782 566900 | +44 1782 563666 |
| DESMI Singapore Pte.Ltd. | No. 8 Kaki Bukit Road 2, Ruby Warehouse Complex Unit no: # 02-13 417841 | Singapore | +65 6748 2481 | +65 6747 6172 |
| DESMI Inc. | HQ, Manufacturing and sales 1119 Cavalier Blvd. Chesapeake, VA 23323 | USA | (757) 857 7041 | (757) 857 6989 |
| DESMI Korea | 503-8, DangSa Ri, Kijang-eup, Kijang-gun Busan | Korea | +82 51 723 8801 +82 70 7723 8804 | +82 51 723 8803 |
| DESMI SARL | 21G rue Jacques Cartier F-78960 Voisins-le-Bretonneux RCS Versailles en cours | France | +33 (0) 1 30 43 97 10 | +33 (0)130 43 97 11 |
| DESMI UAE | Dubai Office Office 307 D-Wing P.O. Box 341489 Dubai Silicon Oasis | UAE | +971-56-300 3422 | |
| DESMI India | 413, Aditya Trade Centre Ameerpet Hyderabad – 500016 | India | +91-9949339054 | |
| DESMI Africa | Plot No.1848 Yacht Club Road Msasani Peninsular Dar es Salaam | Tanzania | +255 757597827 | |
| DESMI Poland | Przedstawicielstwo w Polsce ul. Batalionu Platerówek 3 03-308 Warszawa | Poland | +48 22 676 91 16 | +48 22 618 19 53 |

| Service center - Denmark | | | |
|--------------------------|---|--------------|-----------------|
| City | Address | Telephone | Fax |
| Nørresundby | Tagholm 1 9400 Nørresundby | +45 70236363 | +45 9817 5499 |
| Kolding | Albuen 18 C DK-6000 Kolding | +45 70236363 | +45 75 58 34 65 |
| Aarhus | Lilleringvej 20 DK-8462 Harlev J | +45 70236363 | +49 407 522040 |
| Hvidovre | Stamholmen 173 DK-2650 Hvidovre | +45 70236363 | +45 3677 3399 |
| Odense | Hestehaven 61 DK-5260 Odense S | +45 70236363 | +45 6595 7565 |